

Structure: Silicon Monolithic IC
Product Name Mono Class-D Speaker Amplifier for Portable electronic devices
Part Number **BD5460GUL**

Function/Features

- No output filter required
- Only three external components
- Analog differential input
- Fast turn on time
- Pop noise suppression circuitry
- Standby function
- Protection circuitry (Short protection[Auto recover without power cycling], Thermal shutdown, Under voltage lockout)
- Very small package 9-Bump WL-CSP

Applications

- Mobile phones, PDA, Portable electronic devices, Note-book PC, etc.

■ Absolute Maximum Ratings (Ta=+25°C)

Item	Symbol	Rating	Unit
Power Supply Voltage	VDD	7.0	V
Power Dissipation	Pd	690 (*1)	mW
Operation Temperature Range	Topr	-40 ~ +85	°C
Storage Temperature Range	Tstg	-55 ~ +150	°C
STBY Terminal Input Range	Vstby	-0.1 ~ VDD+0.1	V
IN+, IN- Terminal Input Range	Vin	-0.1 ~ VDD+0.1	V

(*1) ROHM standard board mounted (Board size 50mm × 58mm), derating in done at -5.52mW/°C above Ta=+25°C.

■ Operating Conditions (Ta=+25°C)

Item	Symbol	Rating	Unit
Power Supply Voltage	VDD	+2.5 ~ +5.5	V

※ This product is not designed for protection against radioactive rays.

■ Electric Characteristics

(Unless otherwise specified, Ta=+25°C, VDD=+3.6V, f=1kHz, RL=8Ω, AC item=LC Filter ; L=22μH, C=1μF)

Item	Symbol	Rating			Unit	Conditions
		MIN.	TYP.	MAX.		
Circuit current (No signal)	I _{CC}	—	2.0	4.0	mA	Active mode, No load
Circuit current (Standby)	I _{STBY}	—	0.1	2	μA	Standby mode
Output power 1	P _{O1}	450	680	—	mW	BTL, f=1kHz, THD+N=1% *1
Output power 2	P _{O2}	550	850	—	mW	BTL, f=1kHz, THD+N=10% *1
Voltage gain	G _V	5.4	5.9	6.4	dB	BTL
Output offset voltage	ΔV _o	-25	0	+25	mV	BTL, Vin=0V
Switching Frequency	f _{osc}	175	250	325	kHz	
Start-up time	T _{on}	0.39	0.51	0.73	msec	
STBY threshold voltage	V _{STBY}	0.4	—	1.4	V	Active to standby shift

*1 : B.W.=400~30kHz, BTL: The voltage between A3 and C3

■ Measurement Circuit Diagram

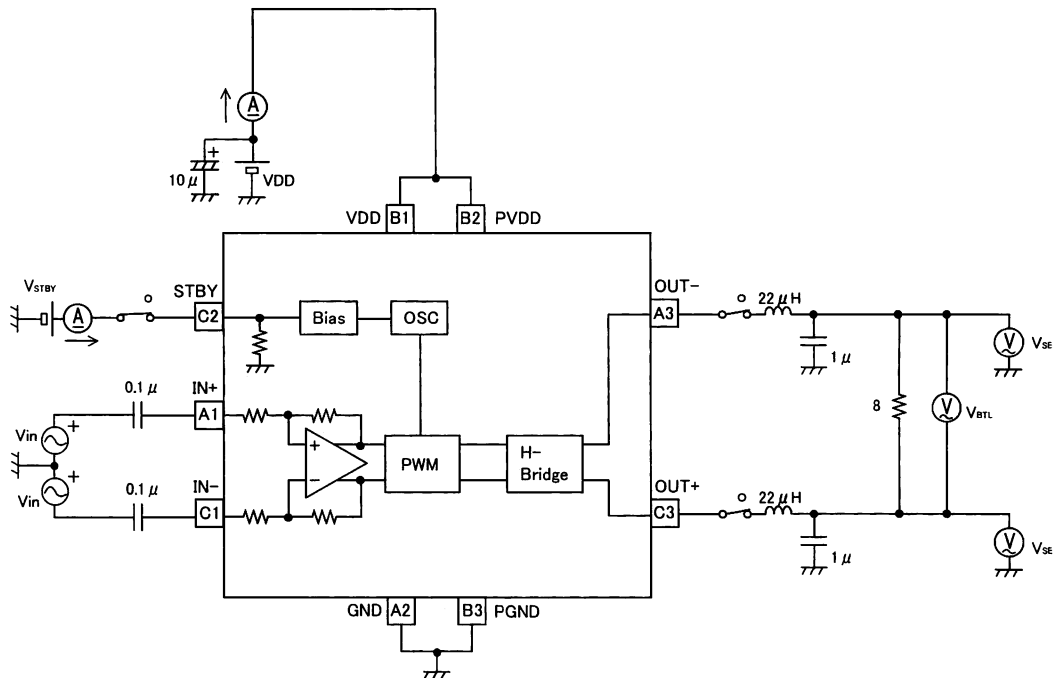

■ Active / Standby Control

STBY Pin (C2pin)

Mode	Pin level	Conditions
Active	H	IC active
Standby	L	IC shutdown

■ Package Outlines

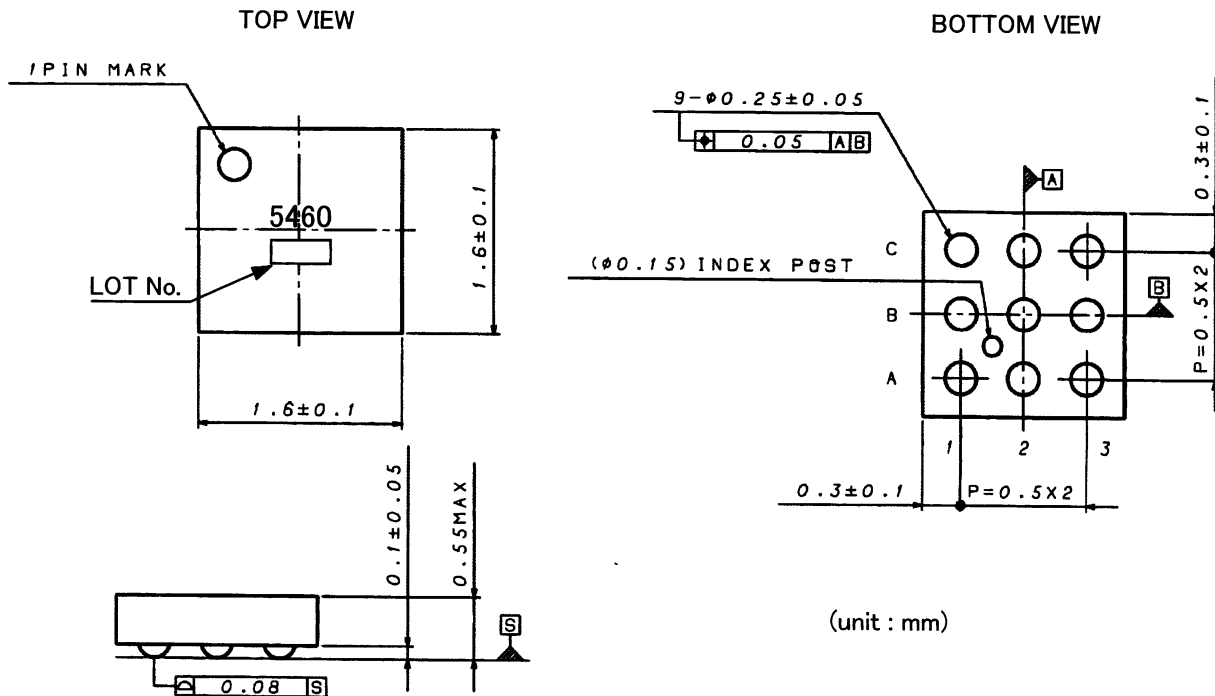

WL-CSP : VCSP50L1

■ Block Diagram

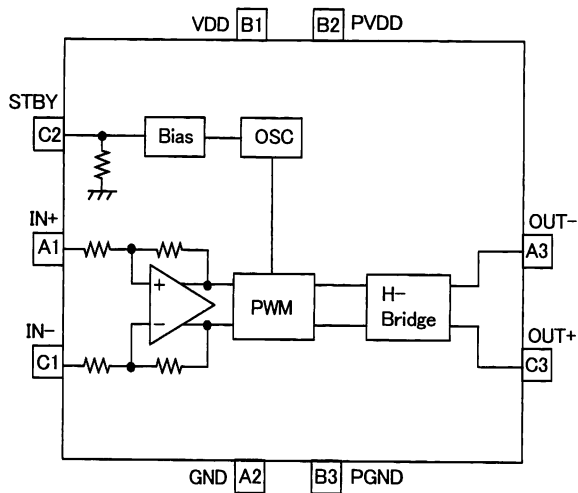

■ Pin Assignment

Pin No.	Pin Name
A1	IN+
A2	GND
A3	OUT-
B1	VDD
B2	PVDD
B3	PGND
C1	IN-
C2	STBY
C3	OUT+

■ Cautions on use**(1) Absolute maximum ratings**

This IC may be damaged if the absolute maximum ratings for the applied voltage, temperature range, or other parameters are exceeded. Therefore, avoid using a voltage or temperature that exceeds the absolute maximum ratings.

If it is possible that absolute maximum ratings will be exceeded, use fuses or other physical safety measures and determine ways to avoid exceeding the IC's absolute maximum ratings.

(2) GND terminal's potential

Try to set the minimum voltage for GND terminal's potential, regardless of the operation mode.

(3) Shorting between pins and mounting errors

When mounting the IC chip on a board, be very careful to set the chip's orientation and position precisely.

When the power is turned on, the IC may be damaged if it is not mounted correctly.

The IC may also be damaged if a short occurs (due to a foreign object, etc.) between two pins, between a pin and the power supply, or between a pin and the GND.

(4) Operation in strong magnetic fields

Note with caution that operation faults may occur when this IC operates in a strong magnetic field.

(5) Thermal design

Ensure sufficient margins to the thermal design by taking in to account the allowable power dissipation during actual use modes, because this IC is power amp. When excessive signal inputs which the heat dissipation is insufficient condition, it is possible that thermal shutdown circuit is active.

(6) Thermal shutdown circuit

This product is provided with a built-in thermal shutdown circuit. When the thermal shutdown circuit operates, the output transistors are placed under open status. The thermal shutdown circuit is primarily intended to shut down the IC avoiding thermal runaway under abnormal conditions with a chip temperature exceeding $T_{jmax} = +150^{\circ}\text{C}$, and is not intended to protect and secure an electrical appliance.

(7) Load of the output terminal

This IC corresponds to dynamic speaker load, and doesn't correspond to the load except for dynamic speakers.

(8) The short protection of the output terminal

The short-circuiting protection of this IC corresponds only to "VDD-short" (the short-circuiting with the power) of the output terminal and "GND-short" (the short-circuiting with GND) of the output terminal. It doesn't correspond to the short-circuiting among the output terminals.

Also, when the short-circuiting condition of the output terminal is canceled, it detects the high impedance of the output terminal and it is equipped with the auto recover without power cycling(the cancellation) function in the short-circuiting protection.

Be careful of the output terminal, because, there is a fear not to return automatically when the short-circuiting condition occurs in pull-up or the pull-down at equal to or less than about $1\text{M}\Omega$ impedance,

(9) Operating ranges

The rated operating power supply voltage range ($V_{DD}=+2.5\text{V}\sim+5.5\text{V}$) and the rated operating temperature range ($T_a=-40^{\circ}\text{C}\sim+85^{\circ}\text{C}$) are the range by which basic circuit functions is operated. Characteristics and rated output power are not guaranteed in all power supply voltage ranges or temperature ranges.

(10) Electrical characteristics

Electrical characteristics show the typical performance of device and depend on board layout, parts, power supply.

The standard value is in mounting device and parts on surface of ROHM's board directly.

(11) Power decoupling capacitor

Because the big peak current flows through the power line, the class-D amplifier has an influence on the Audio characteristic by the capacitance value or the arrangement part of the power decoupling capacitor.

Arrange a power decoupling capacitor as close as possible to the VDD terminal of IC.

Notes

- No technical content pages of this document may be reproduced in any form or transmitted by any means without prior permission of ROHM CO.,LTD.
- The contents described herein are subject to change without notice. The specifications for the product described in this document are for reference only. Upon actual use, therefore, please request that specifications to be separately delivered.
- Application circuit diagrams and circuit constants contained herein are shown as examples of standard use and operation. Please pay careful attention to the peripheral conditions when designing circuits and deciding upon circuit constants in the set.
- Any data, including, but not limited to application circuit diagrams information, described herein are intended only as illustrations of such devices and not as the specifications for such devices. ROHM CO.,LTD. disclaims any warranty that any use of such devices shall be free from infringement of any third party's intellectual property rights or other proprietary rights, and further, assumes no liability of whatsoever nature in the event of any such infringement, or arising from or connected with or related to the use of such devices.
- Upon the sale of any such devices, other than for buyer's right to use such devices itself, resell or otherwise dispose of the same, no express or implied right or license to practice or commercially exploit any intellectual property rights or other proprietary rights owned or controlled by
- ROHM CO., LTD. is granted to any such buyer.
- Products listed in this document are no antiradiation design.

The products listed in this document are designed to be used with ordinary electronic equipment or devices (such as audio visual equipment, office-automation equipment, communications devices, electrical appliances and electronic toys).

Should you intend to use these products with equipment or devices which require an extremely high level of reliability and the malfunction of which would directly endanger human life (such as medical instruments, transportation equipment, aerospace machinery, nuclear-reactor controllers, fuel controllers and other safety devices), please be sure to consult with our sales representative in advance.

It is our top priority to supply products with the utmost quality and reliability. However, there is always a chance of failure due to unexpected factors. Therefore, please take into account the derating characteristics and allow for sufficient safety features, such as extra margin, anti-flammability, and fail-safe measures when designing in order to prevent possible accidents that may result in bodily harm or fire caused by component failure. ROHM cannot be held responsible for any damages arising from the use of the products under conditions out of the range of the specifications or due to non-compliance with the NOTES specified in this catalog.

Thank you for your accessing to ROHM product informations.

More detail product informations and catalogs are available, please contact your nearest sales office.

ROHM Customer Support System

THE AMERICAS / EUROPE / ASIA / JAPAN

www.rohm.com

Contact us : webmaster@rohm.co.jp